

Zirkonzahn®

Human Zirconium Technology

IMPLANT PROSTHETICS

All Components From A Single Source



WE ASSUME THE RESPONSIBILITY

UP TO 30 YEARS WARRANTY ON IMPLANT ABUTMENTS AND IMPLANTS

For the manufacture of our implant-supported components, we use high-quality titanium Grade 5 (ASTM F136; DIN EN ISO 5832-2). As one of the world's largest manufacturers, we meet the strictest quality criteria (ISO 13485 CMDCAS). We assume the responsibility for our products and grant therefore, in addition to the legally prescribed warranty obligation, voluntarily up to 30 years warranty on all Zirkonzahn implant abutments used (titanium bases, Multi Unit Abutments, Multi Unit Abutments Angled, Raw-Abutments® as well as the corresponding screws). Within the current Zirkonzahn warranty regulation, we explicitly include in our warranty also implants from other manufacturers used with Zirkonzahn implant abutments.



The Zirkonzahn warranty regulation can be viewed at www.zirkonzahn.com.

EVERYTHING FROM A SINGLE SOURCE

Especially when manufacturing implant restorations it is important to optimally adjust components to one another. From the software for planning the position of the implant, to analogues for capturing already placed implants, titanium bases and Multi Unit Abutments or blanks with a pre-milled implant connection: we produce and develop everything on our own. All components are available for all common implant systems and are fully integrated in our Zirkonzahn Software. With the Zirkonzahn Library Download Center also 3shape and exocad® users can implement the libraries into their modelling software.

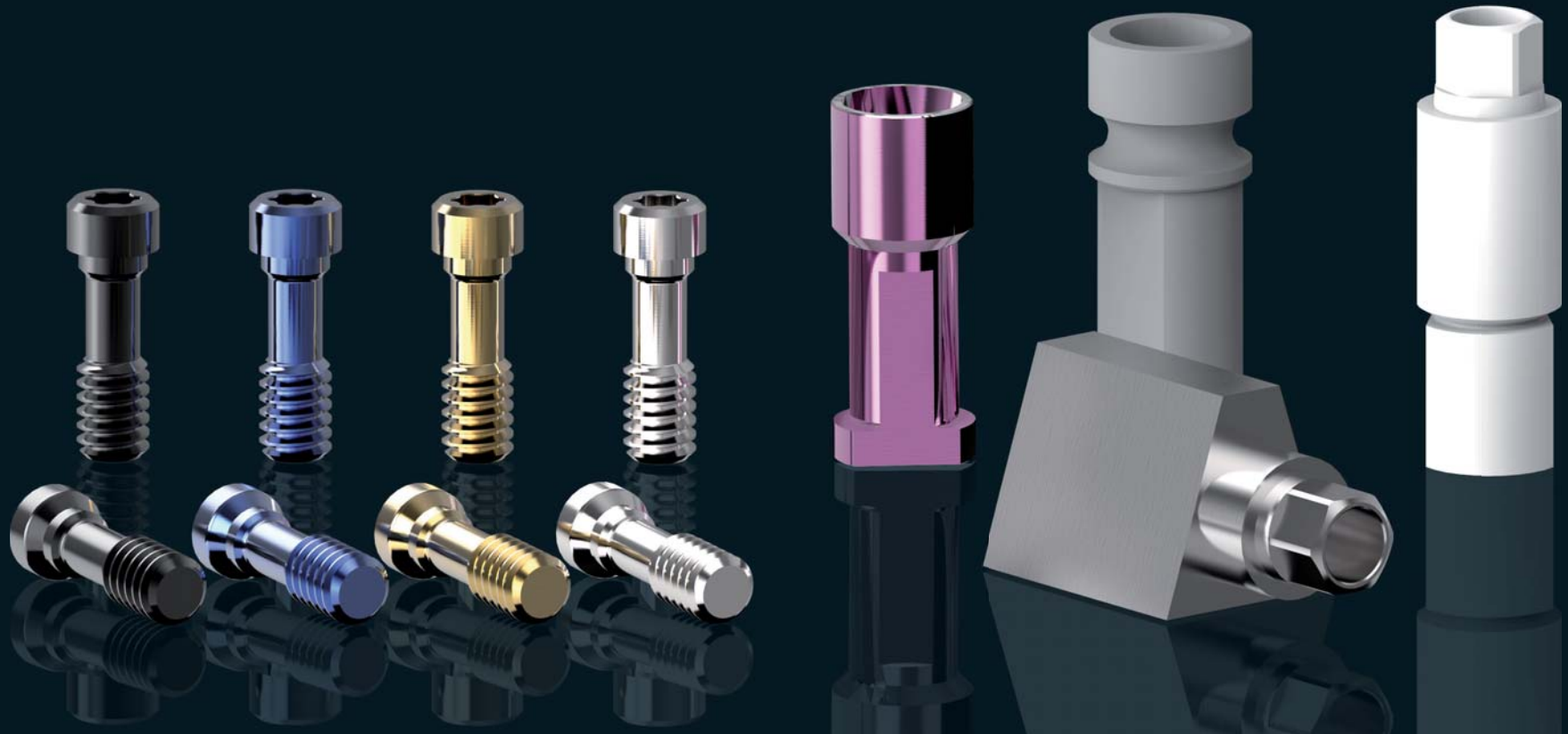



CAPTURE

TITANIUM BASES

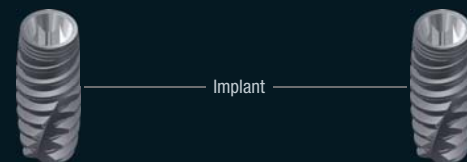
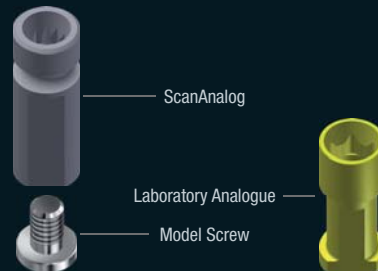
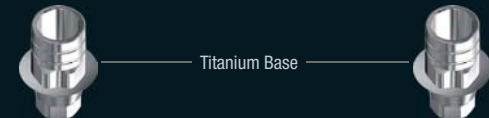
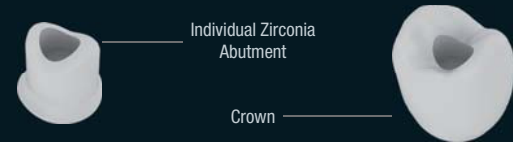
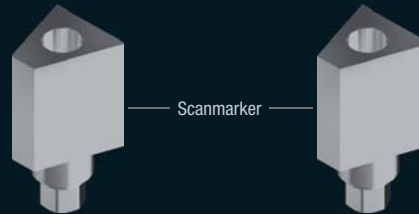
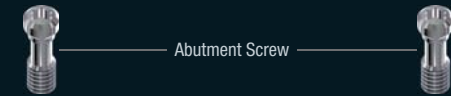
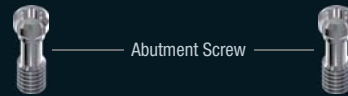
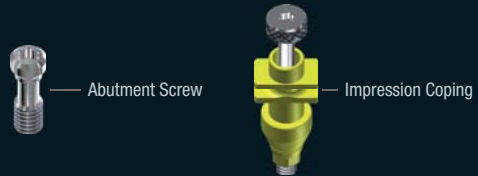

RAW-ABUTMENTS®	MULTI UNIT ABUTMENTS
----------------	----------------------



Crown



Abutment Screw



Healing Cap



Individual Raw-Abutment®



Multi Unit Abutment



Bar



Crown



Multi Unit Abutment Screw



Individual Zirconia Abutment



Crown



Titanium Base



Implant



Implant



Multi Unit Abutment



Implant Screw



Multi Unit Abutment Angled



Implant



CAPTURE

TITANIUM BASES

RAW-ABUTMENTS®

MULTI UNIT ABUTMENTS

ACCESSORIES

OVERVIEW

SOFTWARE

ABUTMENTS FOR ALL COMMON IMPLANT SYSTEMS

Zirkonzahn Multi Unit Abutments (ZZ MUA)	Alpha-Bio Tec® SPI/DFI/ATID	Anthogyr® Axiom®	ASTRA TECH Implant System EV/UniAbutment® EV	ASTRA TECH Implant System OsseoSpeed™	ASTRA TECH UniAbutment®	A-Z Implant® MC	A-Z Implant® VL
BEGO Semados® Mini	BEGO Semados® S/RI/SC/SCX/RS/RSX-Line / MultiPlus System	BioHorizons® External	BioHorizons® Internal	BioHorizons® Multi-unit Abutment	Biomet 3i™ Certain® Implant System	Biomet 3i™ External Connection Implant System (OSSEOTITE®)	Biomet 3i™ Low Profile Abutment
Biotech Dental KONTACT	BrainBase Corporation MYTIS Arrow Implant	Bredent SKY® Classic / blueSKY	Bredent SKY® fast & fixed	Bredent SKY® uni.cone	BTI® Conical Spacer	BTI® Externa®	BTI® Interna®
BTI® Multi-Im®	BTI® Multi-Im® Angled®	BTI® Tiny®	CAMLOG® Bar Abutments (COMFOUR®)	CAMLOG® CONELOG®	CAMLOG® J-Line/K-Line	CAMLOG® VARIO SR	Champions® Implants (R)Evolution
Conmet® Hex	Connect®	Cowellmedi INNO Internal Implant System™	Cumdente	Dentalpoint AG Zeramex® P6	DentalTech ImpLassic®	DentalTech ImpLassic®/Implogic®	Dentium Implantium / SuperLine
Dentium Screw Abutment	Dentsply Sirona® Ankylos® (Friadent) / Balance Base Abutment Narrow	Dentsply Sirona® XiVE® MP/TG	Dentsply Sirona® XiVE®/Frialit	Dyna Dental® Octalock/Helix	FairImplant FairTwo™	GC Tech. Aadva™	Implant Direct™ Legacy™
Implant Direct™ Overdenture Abutment	Intra-Lock® International Internal Implants	Intra-Lock® International UniHex™	K3Pro® Mini Konus/Standard	Klockner® Essential® Cone	Klockner® NK2/SK2	MEDENTIKA® MedentiBASE®	MEDENTIKA® M-Implant

Medentis medical ICX®-templant	Medentis medical ICX-multi®-Konzept	Megagen AnyOne®	Megagen AnyRidge®	MIS® C1	MIS® Multi Unit Abutment	MIS® Multi Unit System	MIS® SEVEN
MIS® V3	Mozo-Grau® Tapered Screw®	Neo Biotech IS	Neoss® ProActive®	Nobel Biocare® Brånemark System® Mkill/Shorty/Groovy® / NobelSpeedy Shorty/ Groovy®	Nobel Biocare® Multi-unit Abutment	Nobel Biocare® NobelActive®/ NobelReplace® CC/ Nobel Parallel CC	Nobel Biocare® NobelReplace®/Replace Select Tapered/ NobelSpeedy®
Nobel Biocare® NobelZygoma	OSSTEM Implant Convertible Abutment	OSSTEM Implant GS/TS	OSSTEM Implant GS/TS Multi Abutment	OSSTEM Implant US	Paltop® Conical Active	Paltop® Internal HEX Connection	PHIBO® TSA® Advance
SIC® invent SICace®	Southern Implants® Deep Conical	Southern Implants® Internal Hex	Southern Implants® IT Connection	Straumann® Bone Level®	Straumann® Multibase Abutment	Straumann® Screw-Retained Abutment	Straumann® Tissue Level (Standard Plus Narrow Neck CrossFit® / SynOcta®)
Sweden & Martina Outlink2	Sweden & Martina P.A.D® Multi Unit Abutment	Sweden & Martina Premium Kohno®	Tekka® In-Kone®	Thommen Medical SPI®	Thommen Medical SPI® VARIOmulti	Warantec Oneplant	Zimmer Dental® Tapered Screw-Vent®
Zimmer Dental® Tapered Screw-Vent® Multi Unit Abutment	...						

The system library is expanded continuously. An overview of all systems stored in the software and information regarding the torques are available at www.zirkonzahn.com/implant-systems or by telephone (+39 0474 066 680).

LABORATORY ANALOGUES

The laboratory analogues made from ASTM-approved titanium Grade 5 replicate the exact position and connection to the implant. This allows to check the fitting accuracy of the final restoration with implant abutments directly on the model. To distinguish the different diameters, the analogues are also available pre-coloured.



HEALING CAPS

Healing caps are used during the healing phase to seal the implant and to define the emergence profile. They can be anodised in different colours or are available already anodised in golden or pink.

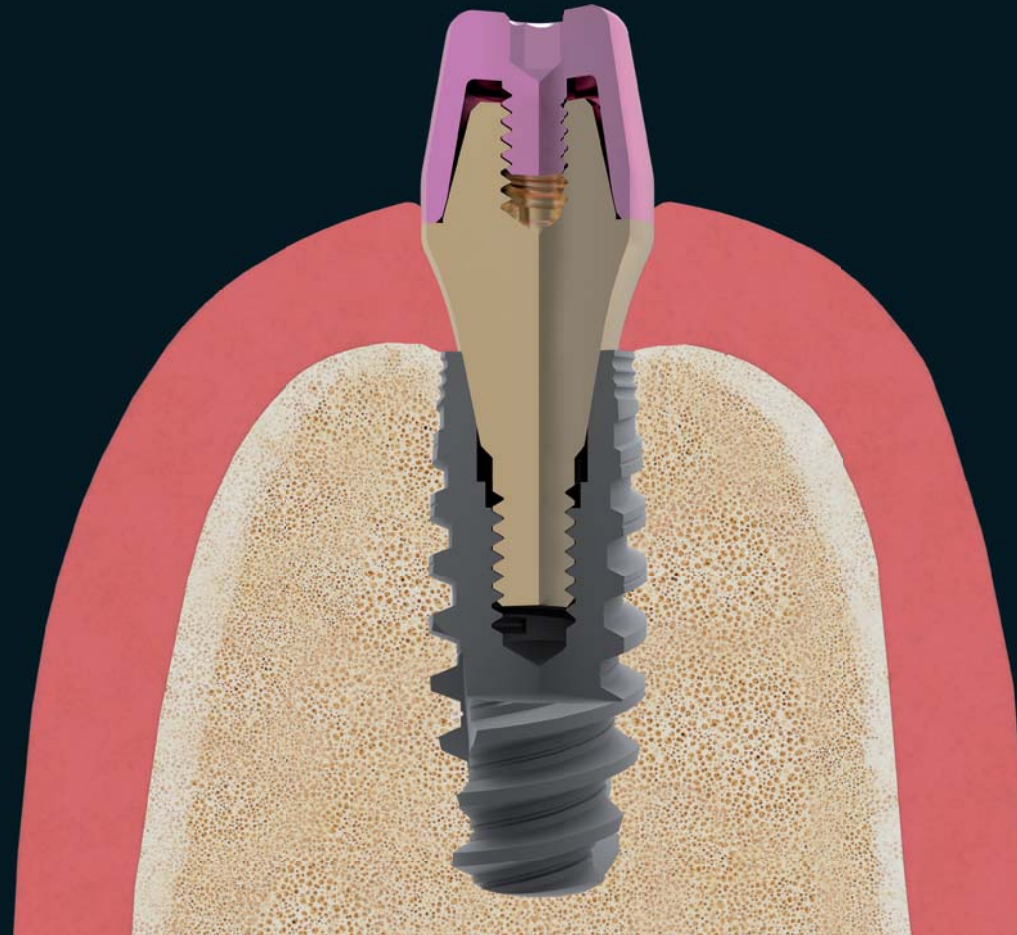

IMPRESSION COPINGS

The stable impression copings are used together with the laboratory analogues for the exact transfer of the implant position in the jaw onto the plaster model or combined with ScanAnalogs in the software.

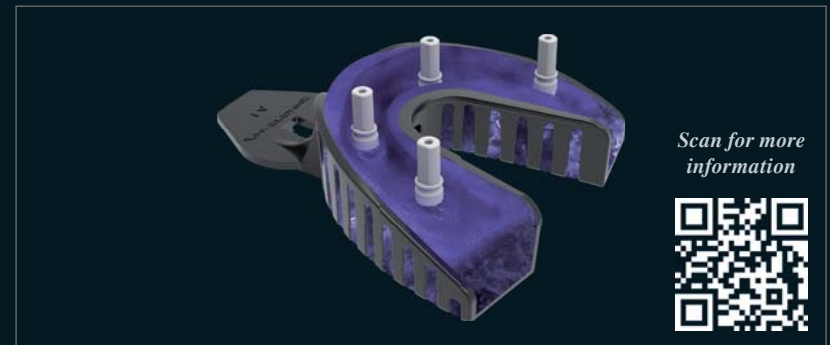
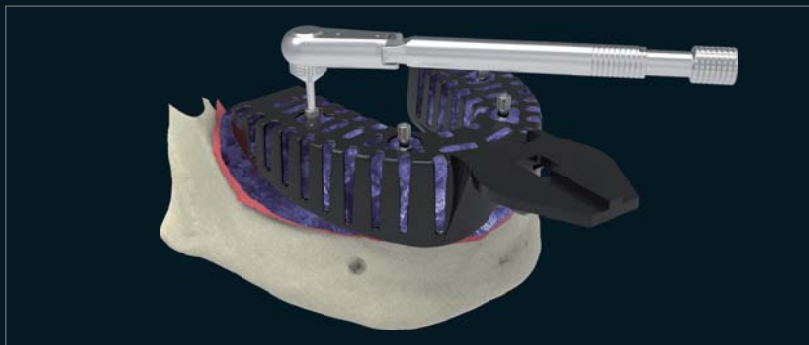
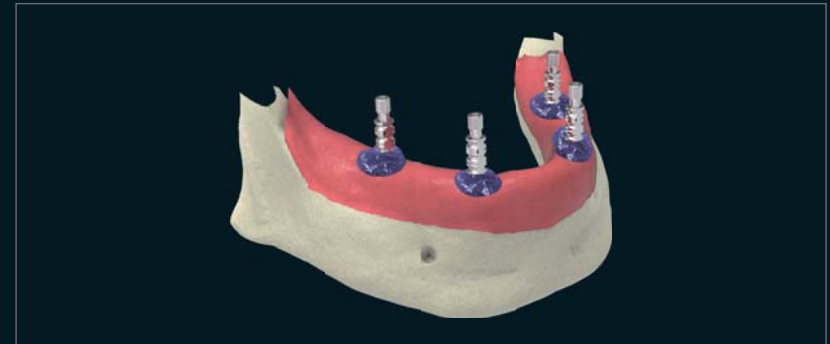
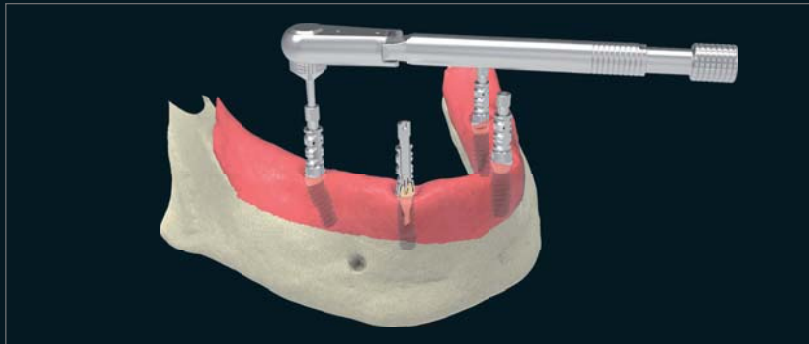

Scan for more information



SCANANALOGS

The ScanAnalogS unite the function of a laboratory analogue with the one of a scanmarker. In contrast to the conventional scanmarker, however, the ScanAnalogS scan directly the impression, not the model. The ScanAnalogS are screwed onto the traditional impression copings in the impression and digitised with the Zirkonzahn scanner. The captured implant position can be directly transferred into the software without a plaster model. Physical models can then be produced from the acquired data (CAD/CAM Model Maker software module). In their role as laboratory analogues they replicate the exact position and orientation of the implants on the model.

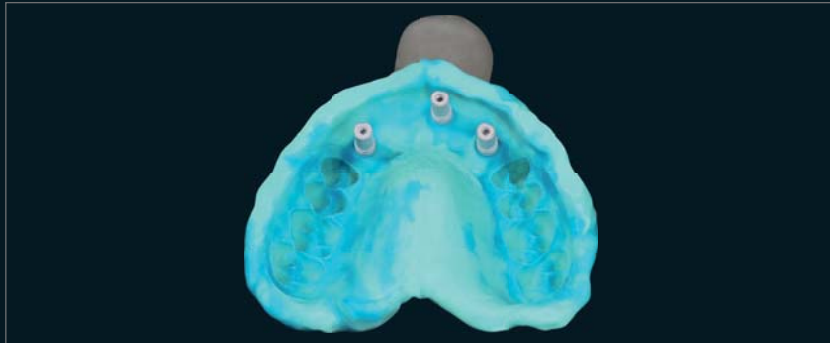

SCANMARKERS

Thanks to the extremely precise geometry of the Scanmarkers and with the aid of the Zirkonzahn scanners, it is possible to transfer the exact position and orientation of the implants from the model into the software.

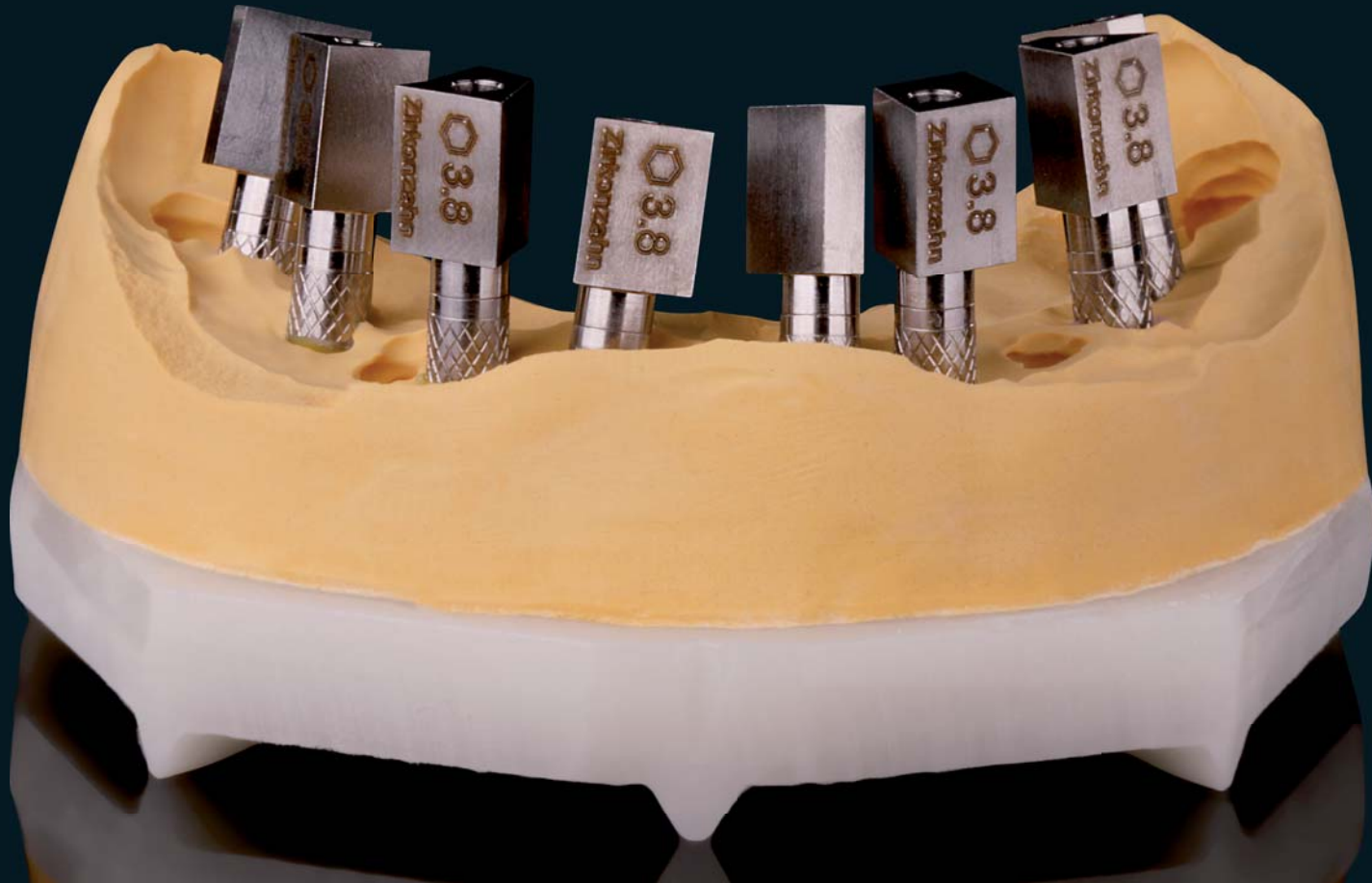

WHITE SCANMARKERS

The White Scanmarkers are used for scans to capture the position and orientation of the implant. The white surface of the scanbody is not reflective, therefore the White Scanmarkers are especially suitable for the application in the patient's mouth. Since the geometry of the White Scanmarkers is held extremely small, scans are also possible with implants that are positioned very deeply or closely together. White Scanmarkers can also be used as Scanmarkers on the plaster model.



TITANIUM BASES

The use of titanium bases reduces the effect of transverse forces on the restoration, in contrast to restorations screwed directly on the implant. We generally recommend the use of titanium bases for all screw-retained implant structures, particularly though for those in the anterior tooth region.

TITANIUM BASES IN 5 HEIGHTS ...

Except for the Narrow titanium bases, the Zirkonzahn titanium bases are available in up to five different platform heights, in order to bring the implant to the desired gingival level. Due to their narrow geometry, the Narrow titanium bases are particularly suitable for use in the anterior tooth sector.

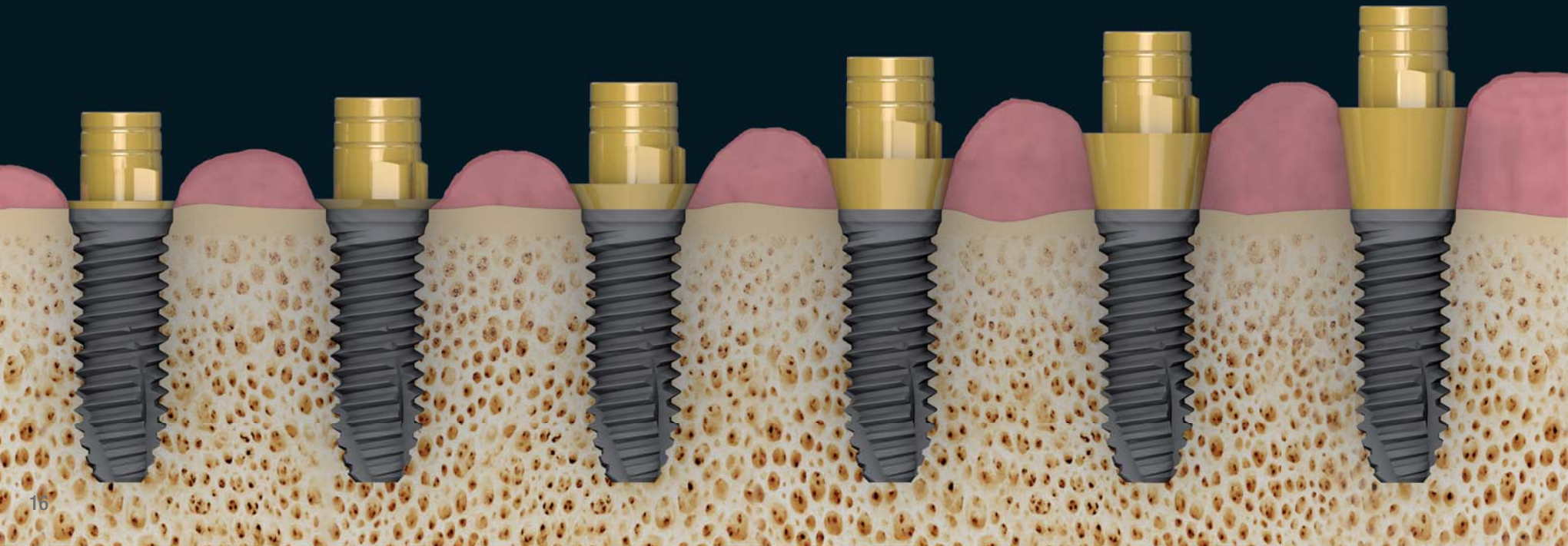

... GOLD-PLATED AND ANODISED

All Zirkonzahn titanium bases are available with a high quality gold plating. The gold coating increases the biocompatibility and the golden shade reduces the grey value of the entire restoration.

Moreover, the titanium bases can also be anodised in different colours using the Zirkonzahn Titanium Spectral-Colouring Anodizer. The high biocompatibility of the material remains unchanged.



CONICAL CEMENTED TITANIUM BASE NON HEX

The Conical Cemented Titanium Bases NON HEX without anti-rotation device are ideal for the manufacturing of bridges and multi-unit restorations. The titanium bases are designed as short and conical as possible. Spiral grooves located on the surface increase the contact area and ensure optimum adhesion of the cement.



For multi-unit restorations



Conical shape with spiral grooves



Also available gold-plated for increased biocompatibility and reduced grey values



Without anti-rotation device



Available in different heights



PARALLEL CEMENTED TITANIUM BASE HEX

The Parallel Cemented Titanium Bases HEX are equipped with the required anti-rotation device depending on the implant system. This ensures that restorations can no longer be twisted once they are cemented. They are especially suitable for single crowns.



For single crowns



Parallel shaft



Also available gold-plated for increased biocompatibility and reduced grey values



With anti-rotation device



Available in different heights



PARALLEL CEMENTED TITANIUM BASE HEX

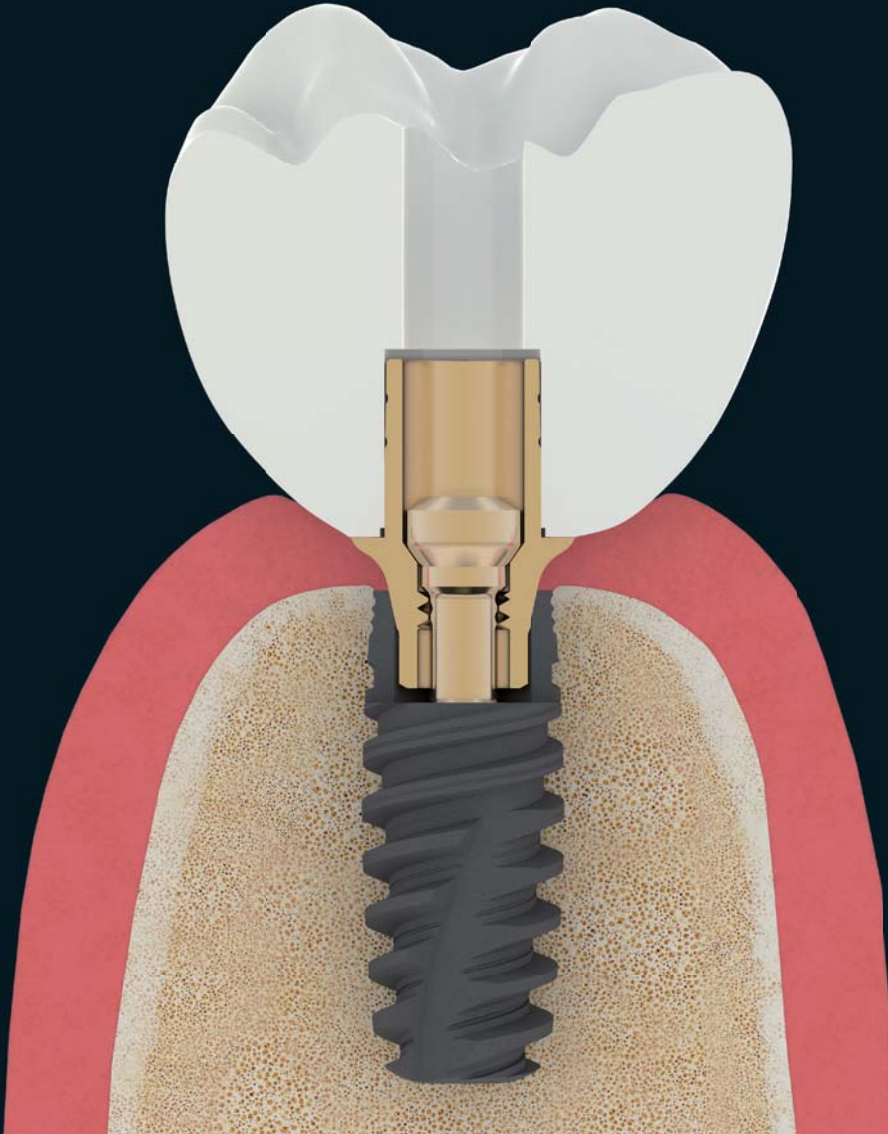

NARROW TITANIUM BASE HEX

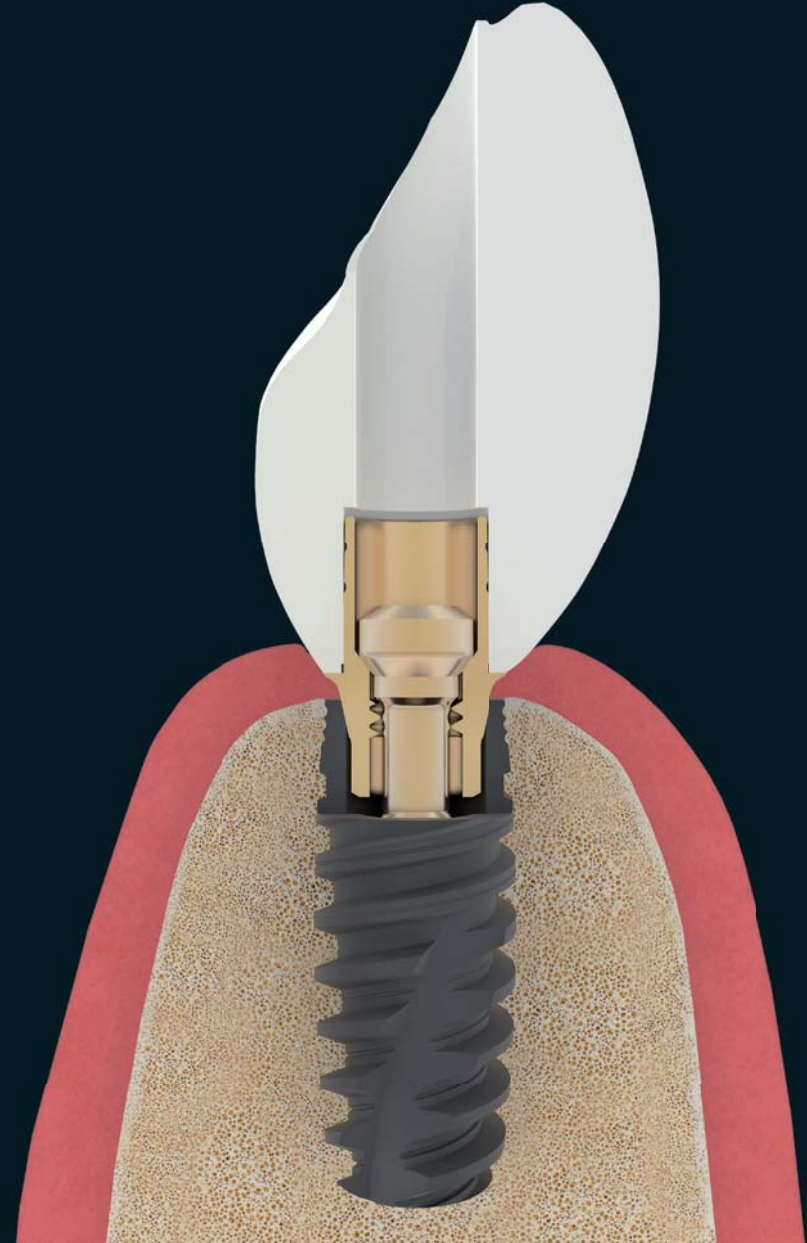

NARROW TITANIUM BASE

The Narrow Titanium Bases are especially advantageous for implants on bone level, since their platform diameter is minimised. This helps to prevent bone atrophy. Thanks to their reduced gingiva height, their metal structure is not visible under the restoration, even if the gingival level is very low or in case of gingival atrophy. They are especially suitable for implants placed closely in the anterior sector where little space is available.

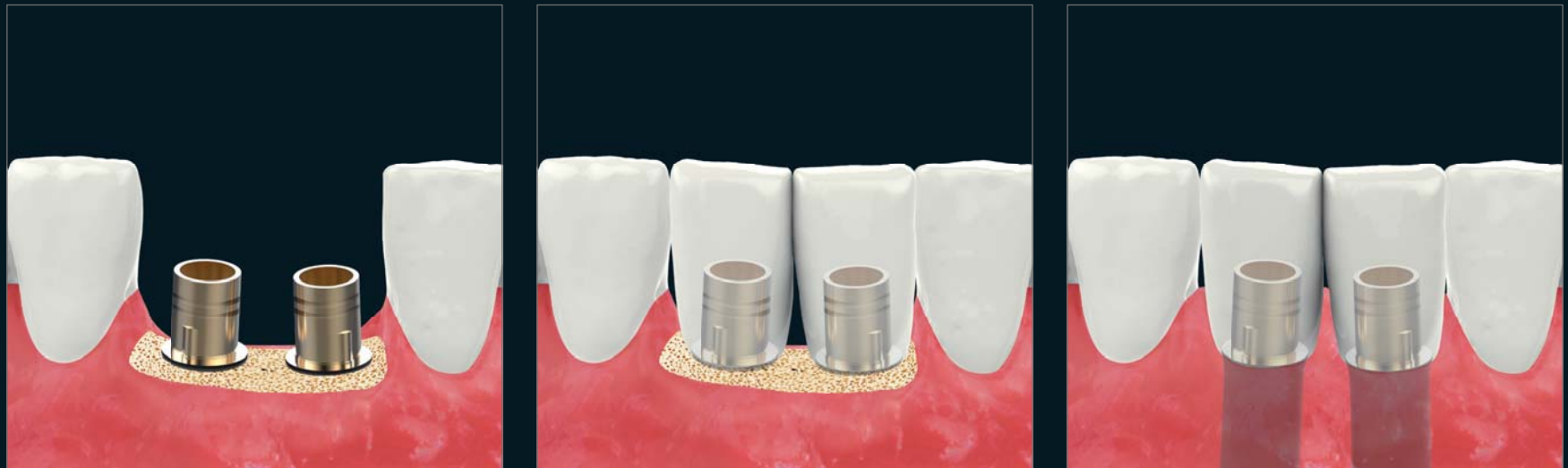

NARROW TITANIUM BASE NON HEX

Thanks to their reduced geometry, the Narrow Titanium Bases NON HEX without anti-rotation device are perfectly suitable for multi-unit restorations on implants placed very closely.



For multi-unit restorations



Conical shape with spiral grooves

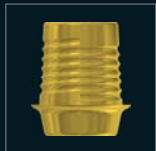

Also available gold-plated for increased biocompatibility and reduced grey values



Without anti-rotation device



NARROW TITANIUM BASE HEX

The Narrow Titanium Bases HEX with anti-rotation device are characterised by their reduced geometry and therefore a perfect solution for single crowns placed next to each other in the anterior tooth region where little space is available.

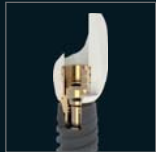

For single crowns



Parallel shaft



Also available gold-plated for increased biocompatibility and reduced grey values



With anti-rotation device



RAW-ABUTMENT® HEX

The Raw-Abutments® made from ASTM-approved titanium Grade 5 are used for the production of individual abutments. The industrially prefabricated implant connection guarantees highest precision and fitting accuracy. The special milling strategies and milling burs ensure a particularly smooth surface structure. The abutment geometry is freely and individually customisable. Depending on the implant system, different Raw-Abutment® blanks are required.



For single crowns



With anti-rotation device



Available with 10 mm and 14 mm diameter



Can be anodised in different colours with the Titanium Spectral-Colouring Anodizer



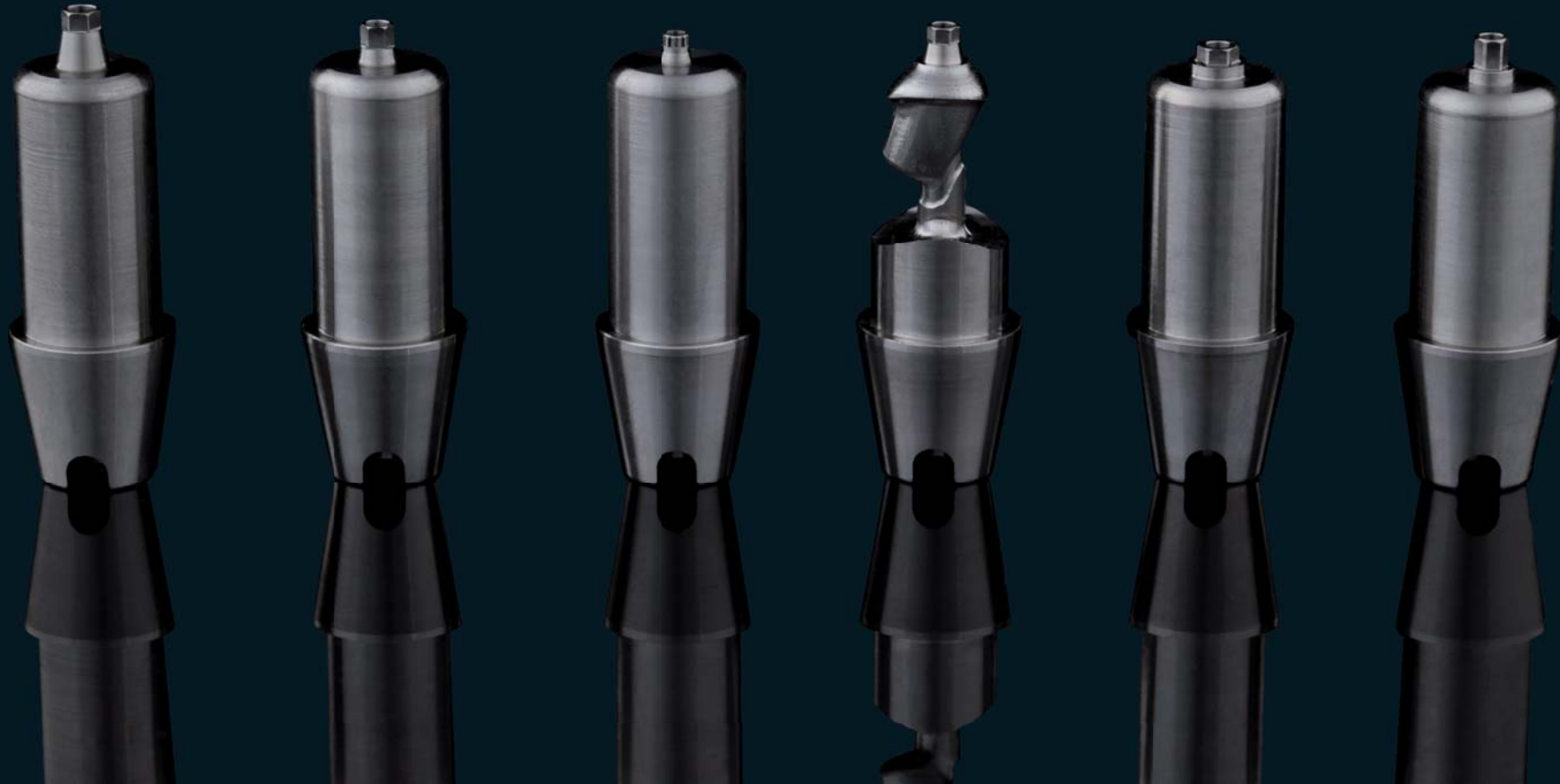

ZIRKONZAHN MULTI UNIT ABUTMENTS

The Zirkonzahn Multi Unit Abutments and Multi Unit Abutments Angled are especially suited for multi-unit restorations. Due to the fact that they are adapted to different implant systems and their connections for the secondary structure are unified, the secondary structure can be screwed directly, or with additional titanium bases, on different implants without any problems. A further advantage of the standardised connection is that using these abutments, also other components (e.g. titanium bases, Scanmarkers, etc.) are reduced to one connection and divergences can be compensated.

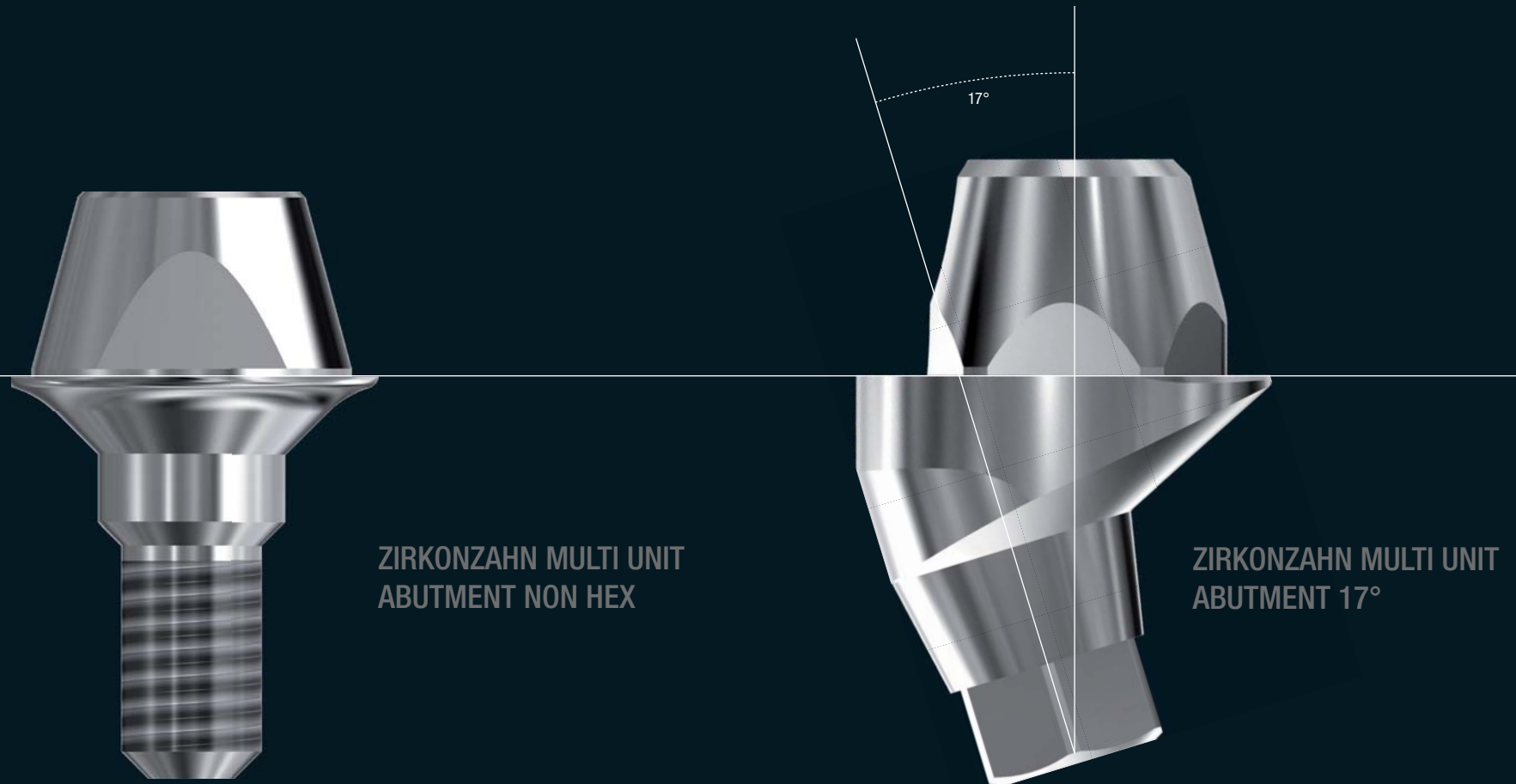

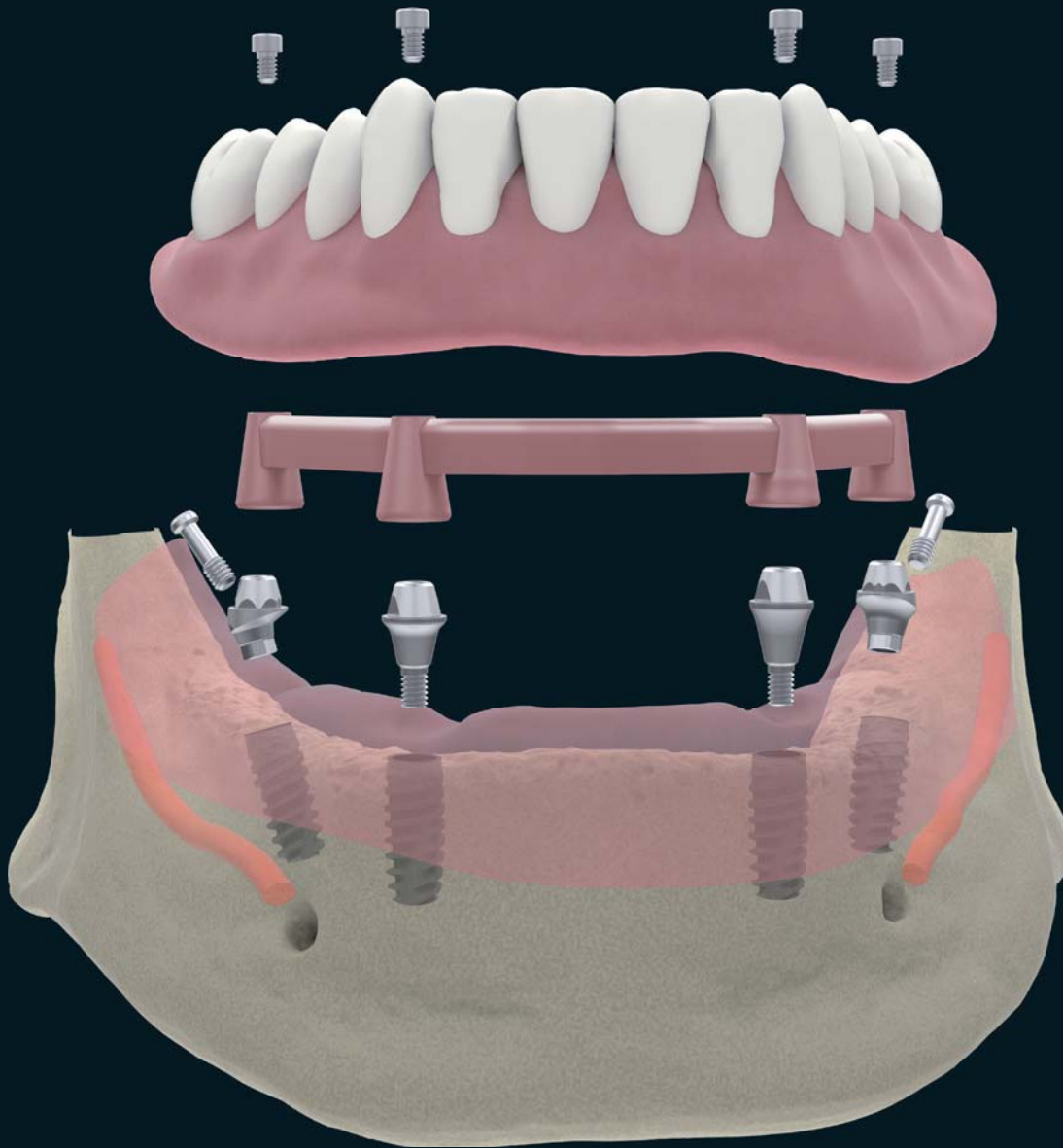

*Restoration fixed on two
Multi Unit Abutments and
two Multi Unit Abutments 17°
which allow to compensate the
implants' diverging axes.*

FOR MULTI-UNIT RESTORATIONS

NON HEX



Conical Cemented Titanium Base NON HEX +
Abutment Screw Metal



Multi Unit Abutment NON HEX +
Abutment Screw Metal



Implant

FOR SINGLE CROWNS

HEX



Narrow Titanium Base HEX Six Position +
Abutment Screw Metal



Narrow Titanium Base HEX One Position +
Abutment Screw Metal



Multi Unit Abutment 17° HEX +
Implant Screw + Insertion Tool

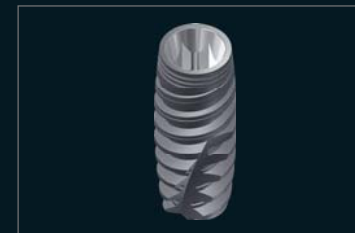

Implant

COMMON COMPONENTS



Impression Coping



Healing Cap Pink; anodised



Scanmarker + Abutment Screw Metal



White Scanmarker + Abutment Screw Metal



Laboratory Analogue



ScanAnalog

TOOLS



Screwdriver 0,05" short



Torque Ratchet Wrench



Screwdriver 0,05" medium



Screw Driver Zirkozahn MUA



Screwdriver 0,05" long

ZIRKONZAHN MULTI UNIT ABUTMENT NON HEX

The Multi Unit Abutments NON HEX without anti-rotation device are suited for multi-unit restorations. They are designed in one piece to prevent the ingress of bacteria. The application of the Multi Unit Abutments NON HEX is extremely easy, because all types of implants have been adapted on a standard port. They are available in five different gingival heights to offer the best possible solution for every case.



For multi-unit restorations



*Conical Cemented Titanium Base
as component of the Multi Unit Abutment*



Without anti-rotation device



*Also available gold-plated for increased biocompatibility
and reduced grey values*



Available in different heights



ZIRKONZAHN MULTI UNIT ABUTMENT ANGLED HEX

The Zirkonzahn Multi Unit Abutments Angled are available with a 17° angle and two differently angled hex-implant connections to compensate any inclinations of the implants. They can be used for single and multi-unit restorations.



For single crowns and multi-unit restorations



Conical Cemented Titanium Base, Parallel Cemented Titanium Base and Parallel Cemented Titanium Base One Position as components of the Multi Unit Abutment Angled HEX. The One Position titanium bases are used to screw single crowns on Multi Unit Abutments 17° with anti-rotation device



With anti-rotation device



Also available gold-plated for increased biocompatibility and reduced grey values



Available in different heights

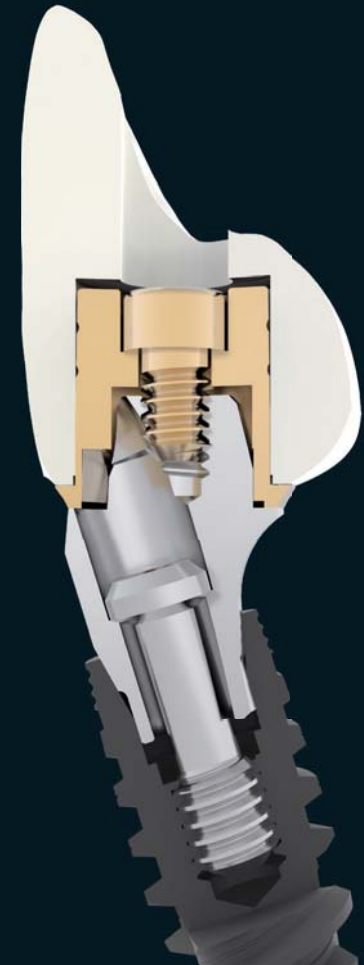

CONNECTION POSSIBILITIES MULTI UNIT ABUTMENT

Depending on the position of the implant, with the two different connection types (1 and 2) the number of connection possibilities has doubled.

Side view

Top view

The MUA can be positioned on every 60° of a HEX connection.

Having the possibility to choose between two different connection types, the MUA can be positioned on every 30° of a HEX connection.

*HEX connection
Type 1*

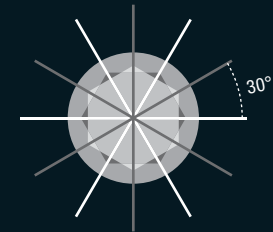
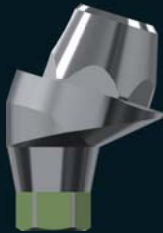

*HEX connection
Type 2*

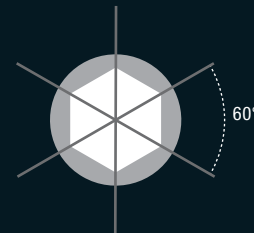
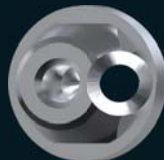

Triangular connection
Type 1

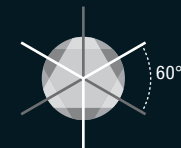

Triangular connection
Type 2



Square connection
Type 1

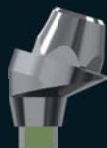

Square connection
Type 2



Octagonal connection
Type 1

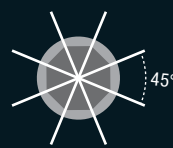

Octagonal connection
Type 2



ABUTMENT SCREW METAL

This abutment screw is suitable to fix titanium bases, Scanmarkers and Raw-Abutments®, but not zirconia structures.



For titanium bases, Scanmarkers and metal structures with direct connection, not for zirconia abutments



With conical or flat screw head



Available gold-plated for increased biocompatibility; gold-plating prevents cold welding as well as the unintended loosening of the screw



Abutment Screw Black: Screw for the final restoration in the patient's mouth



Abutment Screw Laboratory: Provisional screw for fixing the structure on the model

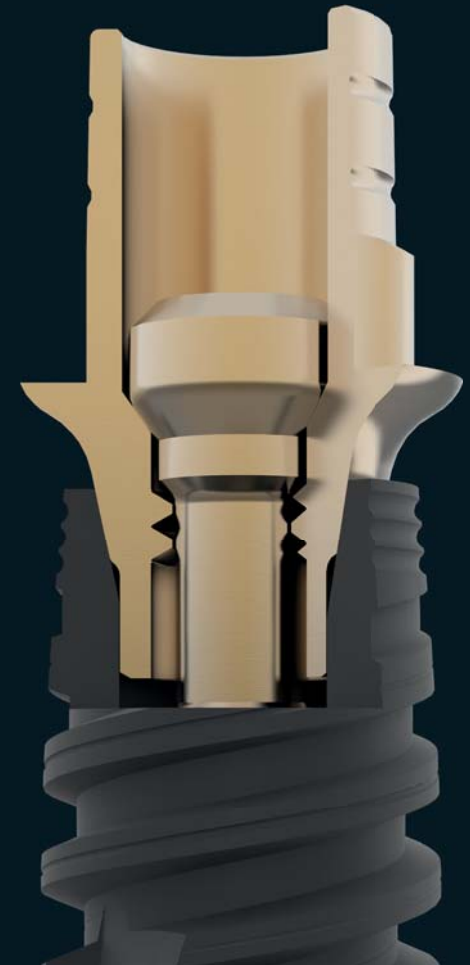

ABUTMENT SCREW ZIRCONIA

This abutment screw with flat screw head is ideal for directly screwed zirconia or resin structures. However, we generally recommend the use of titanium bases for all implant-supported restorations.



For individual abutments made from zirconia and resin



With flat screw head



Available gold-plated for increased biocompatibility; gold-plating prevents cold welding as well as the unintended loosening of the screw



Abutment Screw Black: Screw for the final restoration in the patient's mouth



Abutment Screw Laboratory: Provisional screw for fixing the structure on the model



APPLICATION

Titanium bases, Raw-Abutments® and Scanmarkers can be fixed onto the implant using the Abutment Screw Metal. On full-contour zirconia abutments, screws with flat seating must be used, in order to avoid tensions in the zirconia which, in the worst case, can lead to cracks in the abutment.



or



ABUTMENT SCREW METAL

The screw head can be conical or flat, depending on the implant system

only



ABUTMENT SCREW ZIRCONIA

Only with flat screw head for monolithic zirconia and resin

RIGHT

Abutment Screw
Zirconia



Zirconia Abutment



Implant



RIGHT

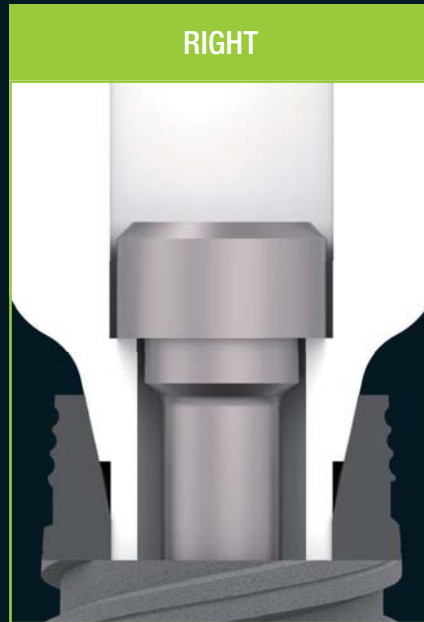

WRONG

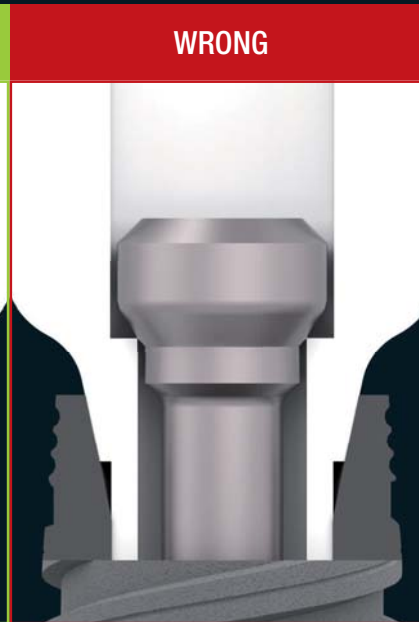

WRONG

Abutment Screw
Metal



Zirconia Abutment



Implant



TOOLS

Torque Ratchet Wrench



Screwdriver Zirkonzahn MUA



Screwdriver 0,05" short



Screwdriver 0,05" medium



Screwdriver 0,05" long



Universal Extractor 1,6 - 1,9



Universal Extractor 2,0 - 2,4



Sealing Screw Extractor





Titanium Base Extractor Biotech® 3,0-5,4



Titanium Base Extractor Camlog® 3,3-4,3



Titanium Base Extractor Camlog® 5,0



Titanium Base Extractor Dentsply Sirona Ankylos 3,5-7,0



Titanium Base Extractor K3® 2 mm



Titanium Base Extractor K3® 3 mm



Titanium Base Extractor NobelActive NP



Titanium Base Extractor NobelActive RP/WP



Titanium Base Extractor Tekka® In-Kone®

TITANIUM BASE EXTRACTOR

Abutments and laboratory analogues or implants are fitted on the master model or in the patient's mouth and then screwed. If the abutment is fixed on an implant with a flat-angled connection, a frictional connection is created. In the conventional manual way, the two components cannot be separated from each other without sustaining some damage. By using the Titanium Base Extractor this is possible without overstressing the osseointegrated parts.

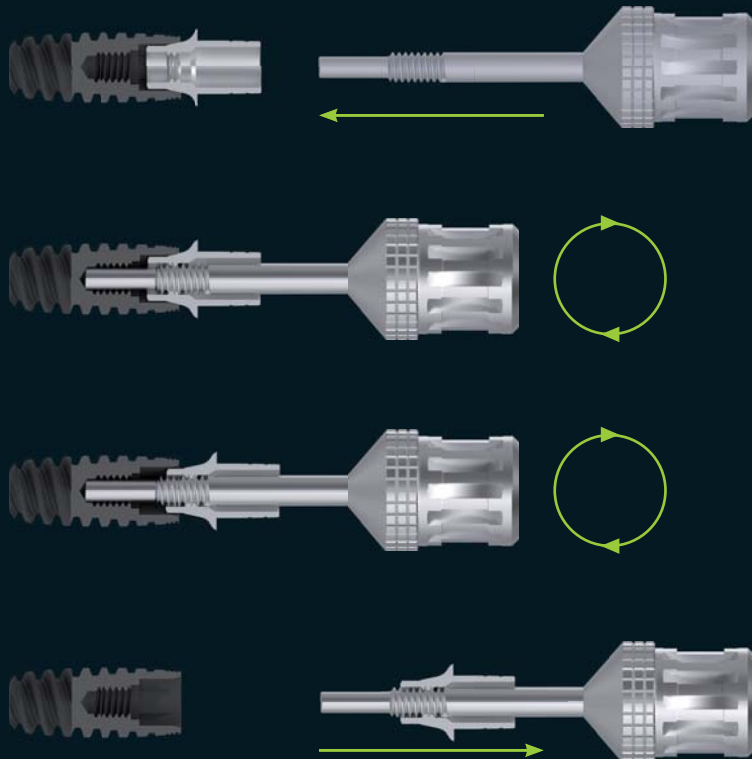

The Titanium Base Extractor is screwed into the internal thread of the abutment ...

... until the bottom of the implant is reached.

A further screwing ...

... ensures a gentle removal of the abutment from the implant or laboratory analogue.

UNIVERSAL EXTRACTOR

The Universal Extractor is used to remove directly screwed secondary structures (e.g. made of metal or resin) as well as titanium bases without internal threads from implants with flat-angle connection geometries.

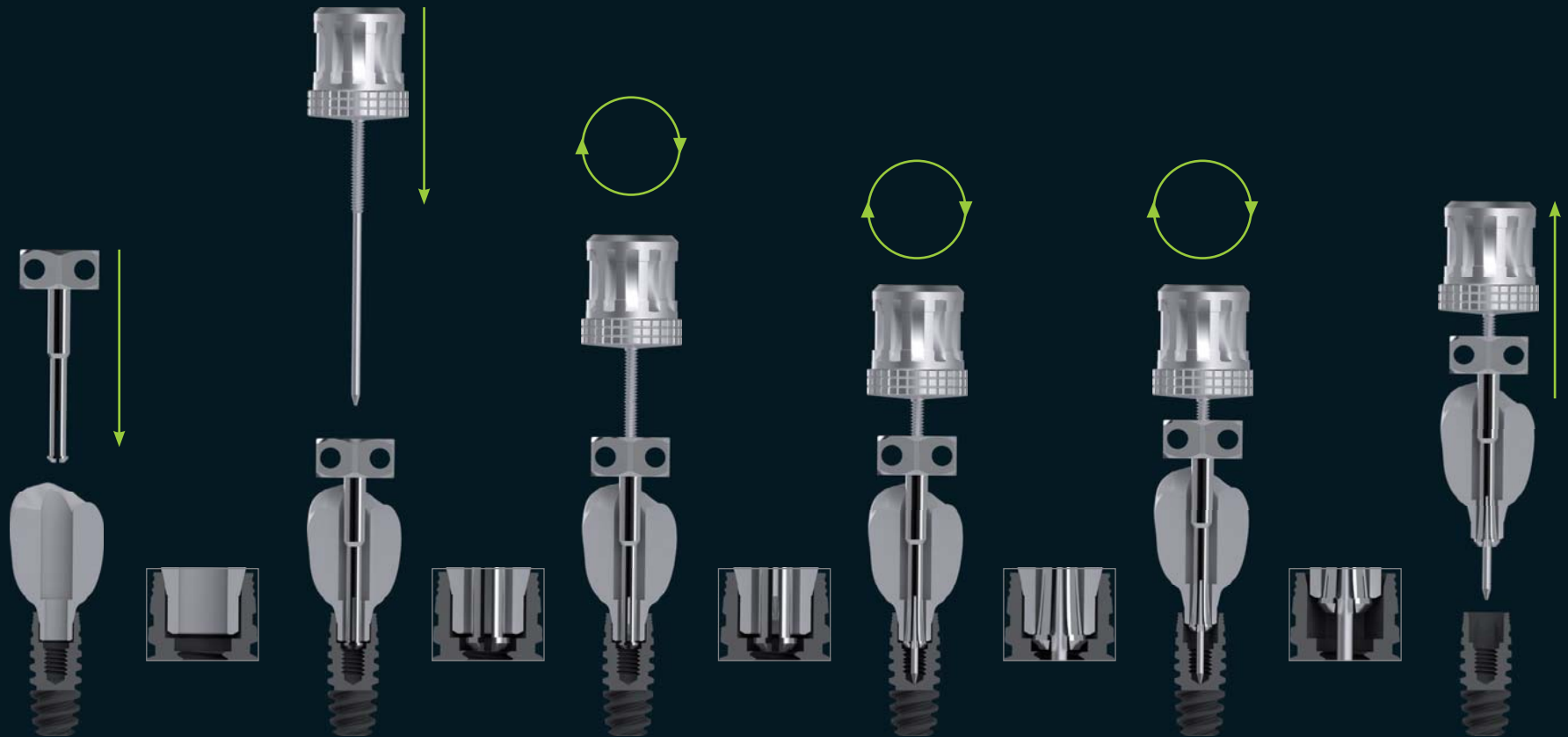

SCREWDRIVER ZIRKONZAHN

*The screwdrivers are used in combination with the Torque Ratchet Wrench torque wrench to fix the titanium bases and MUAs.
The screwdrivers are available in different sizes.*

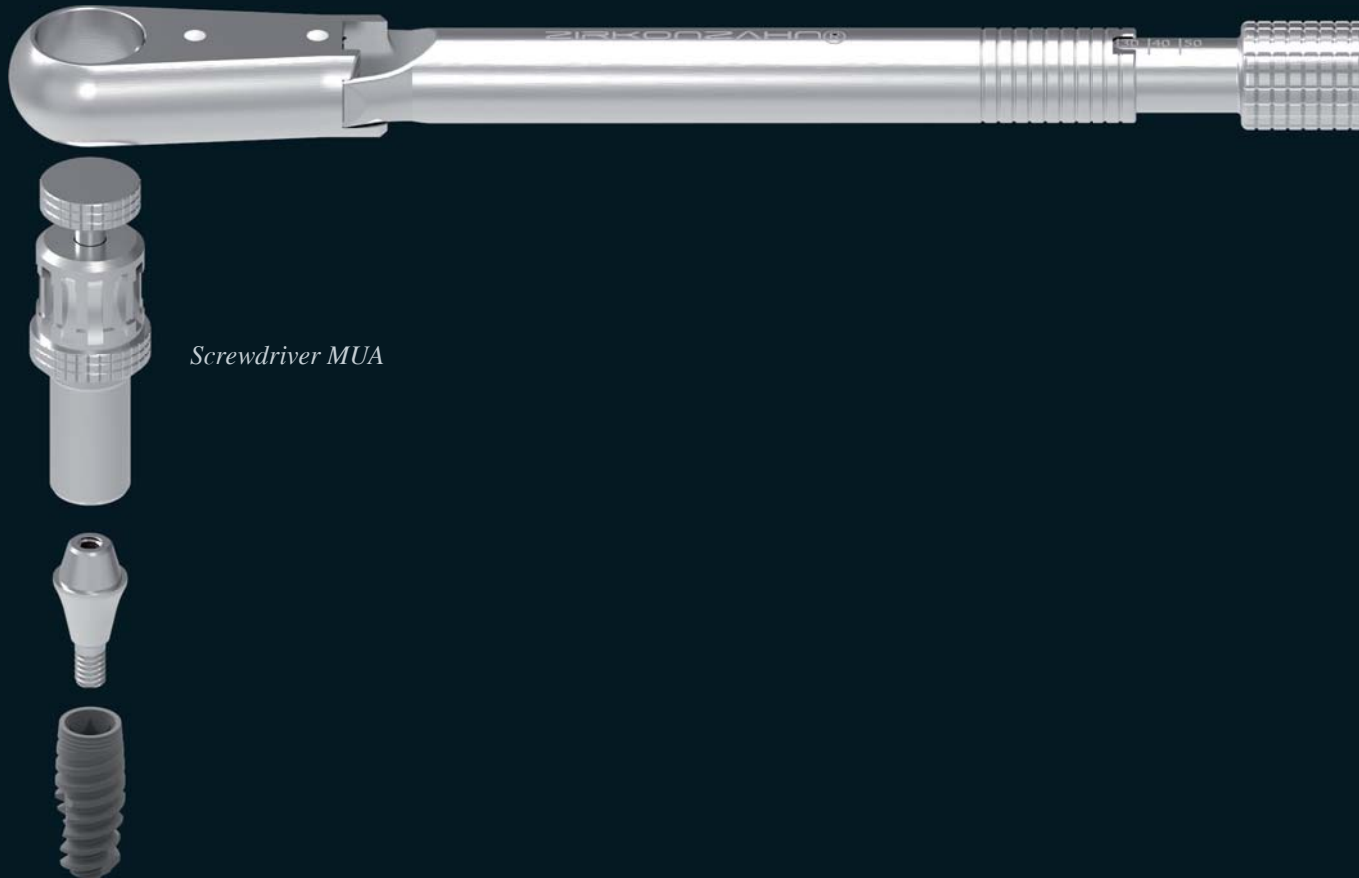







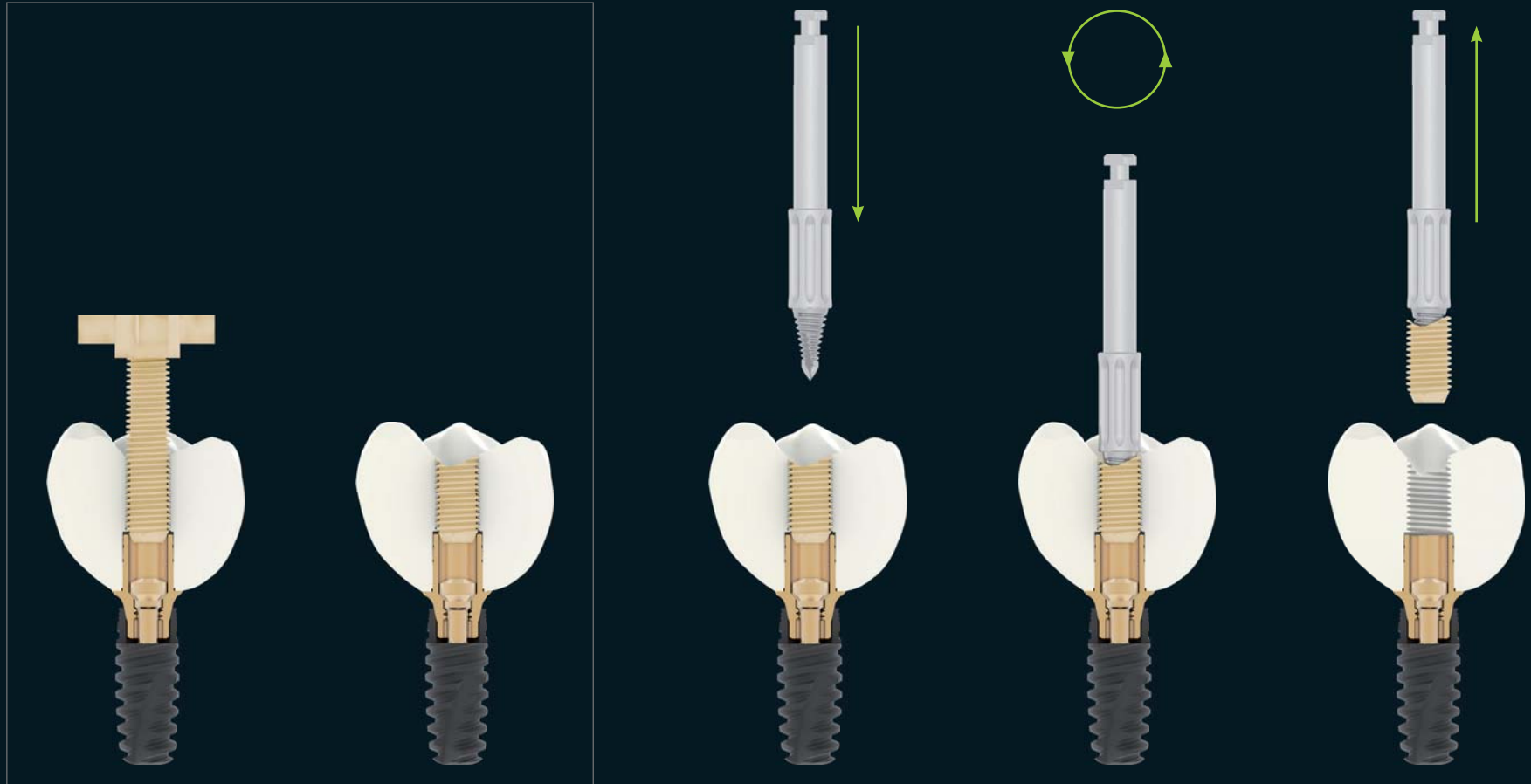



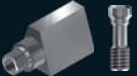



Screwdriver MUA

SEALING SCREW EXTRACTOR

The Sealing Screw Extractor can be used to loosen sealing screws out of zirconia structures without damaging the threaded screw channel.



AVAILABLE SETS







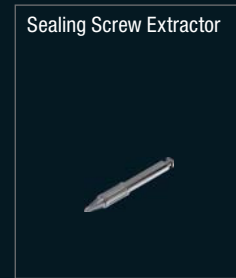
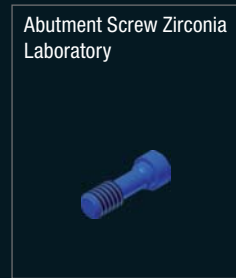
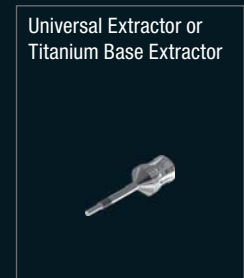
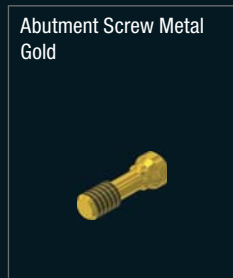



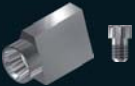



ANALOGUES	SCANMARKER	RAW-ABUTMENTS®	TITANIUM BASES			
<p>Laboratory Analogue</p> 	<p>Scanmarker + Abutment Screw Metal</p> 	<p>Raw-Abutment® HEX + Abutment Screw Metal</p> 	<p>Narrow Titanium Base HEX + Abutment Screw Metal</p> 	<p>Narrow Titanium Base HEX Gold + Abutment Screw Metal Gold</p> 	<p>Parallel Cemented Titanium Base HEX + Abutment Screw Metal</p> 	<p>Parallel Cemented Titanium Base HEX Gold + Abutment Screw Metal Gold</p> 
<p>LOC-Connector</p> 	<p>White Scanmarker + Abutment Screw Metal</p> 	<p>Raw-Abutment® D14 HEX + Abutment Screw Metal</p> 	<p>Narrow Titanium Base NON HEX + Abutment Screw Metal</p> 	<p>Narrow Titanium Base NON HEX Gold + Abutment Screw Metal Gold</p> 	<p>Conical Cemented Titanium Base NON HEX + Abutment Screw Metal</p> 	<p>Conical Cemented Titanium Base NON HEX Gold + Abutment Screw Metal Gold</p> 
<p>ScanAnalog</p> 						





















SCREWS

TOOLS



AVAILABLE SETS ZIRKONZAHN MUA

ANALOGUES	SCANMARKER	TRANSFER	HEALING CAPS	MULTI UNIT ABUTMENT		TITANIUM BASES
<p>Laboratory Analogue</p> 	<p>Scanmarker + Abutment Screw Metal</p> 	<p>Impression Coping</p> 	<p>Healing Cap Grey; anodisable</p> 	<p>Multi Unit Abutment NON HEX + Abutment Screw Metal</p> 	<p>Multi Unit Abutment NON HEX Gold + Abutment Screw Metal Gold</p> 	<p>Conical Cemented Titanium Base NON HEX + Abutment Screw Metal</p> 
	<p>White Scanmarker + Abutment Screw Metal</p> 		<p>Healing Cap Golden; anodised</p> 	<p>Multi Unit Abutment 17° HEX + Implant Screw + Insertion Tool</p> 	<p>Multi Unit Abutment 17° HEX Gold + Implant Screw Gold + Insertion Tool</p> 	<p>Narrow Titanium Base HEX + Abutment Screw Metal</p> 
<p>ScanAnalog</p> 			<p>Healing Cap Pink; anodised</p> 			<p>Narrow Titanium Base HEX One Position + Abutment Screw Metal</p> 

TITANIUM BASES	SCREWS				TOOLS	
Conical Cemented Titanium Base NON HEX Gold + Abutment Screw Metal Gold 	Abutment Screw Metal 	Abutment Screw Metal Gold 	Abutment Screw Metal Laboratory 	Abutment Screw Metal Black 	Screw Driver Zirkonzahn MUA 	Screwdriver 
Narrow Titanium Base HEX Gold + Abutment Screw Metal Gold 	Abutment Screw Zirconia 	Abutment Screw Zirconia Gold 	Abutment Screw Zirconia Laboratory 	Abutment Screw Zirconia Black 	Torque Ratchet Wrench 	Titanium Base Extractor 
Narrow Titanium Base HEX One Position Gold + Abutment Screw Metal Gold 	Implant Screw 	Implant Screw Gold 	Implant Screw Laboratory 	Implant Screw Black 	Sealing Screw Extractor 	

ZIRKONZAHN.SOFTWARE

When developing the Zirkonzahn.Software we adapted the strict quality standards of our proven products to our software's design and functionality. The user's interface is clearly structured, has a simple design and is the same for each software component, which makes it the cornerstone for a familiar and reliable application. When it comes to the creation of different features, our developing team, which obviously includes also dental technicians, follows a practical and result-oriented principle, which guarantees the greatest possible freedom of choice and processing. Furthermore, complex technological processes are designed in a comprehensive and transparent way. The different software programmes with the corresponding modules are not only matched to each other but also to the related hardware components. This ensures a 100% smooth work process for the dental technician and the dentist – from the patient registration, articulation, modellation, realisation, to the insertion of the restoration in the patient's mouth. Proven manual and digital working techniques are combined in order to achieve the best possible patient care.



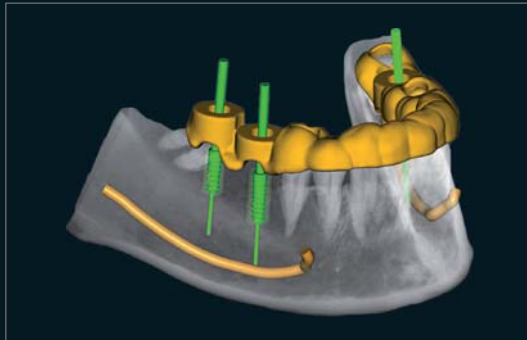

ZIRKONZAHN.IMPLANT-PLANNER

- 3D implant planning software on the basis of matched patient data (DICOM data, model scans and 3D facial scans etc.)
- Compatible with DICOM data of any CT and Cone Beam device
- Easy to use interface
- The software allows the import of any optical pre-operative scanning file, from intraoral or lab scanners
- Includes virtual implant libraries of the most common implant systems
- Open interface for exporting all planning data
- Safe and secure data exchange between the dentist and dental technician

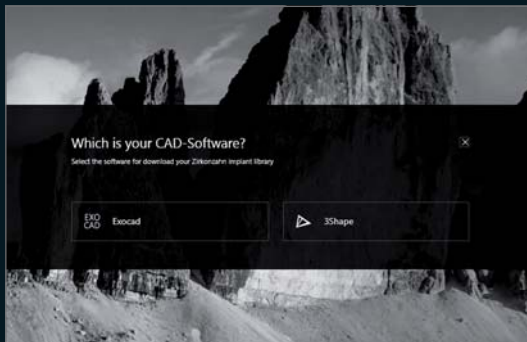

ZIRKONZAHN LIBRARY DOWNLOAD CENTER

- Zirkonzahn implant components for exocad® and 3shape users
- Free programme to import and manage all of Zirkonzahn's implant components (laboratory analogues, Scanmarkers, White Scanmarkers, titanium bases, MUAs) in the 3shape or exocad® modelling software
- Fast download: Implant libraries can be downloaded individually
- Always up to date: automatic update information for newly available systems or system components

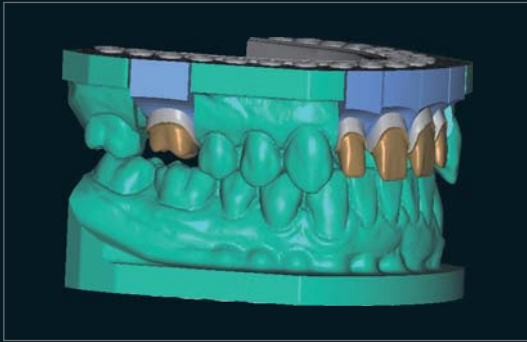

THE CAD/CAM MODEL MAKER SOFTWARE MODULE

- *Module for the manufacture of different physical models (e.g. Geller models, models with implant analogues, dies, full-arch bridges) based on intraoral scan data as well as impression scans and model scans*
- *Articulating scan data with different kinds of connections (e.g. special positioning plates for split-cast system or mini articulators)*
- *Automatic alignment of the scan data in occlusion*
- *Customised setting of the parameters (distance between model and die, model thickness etc.)*
- *Automatic margin and undercut identification (ditching)*
- *Exportable data for manufacturing models with 3D printers*

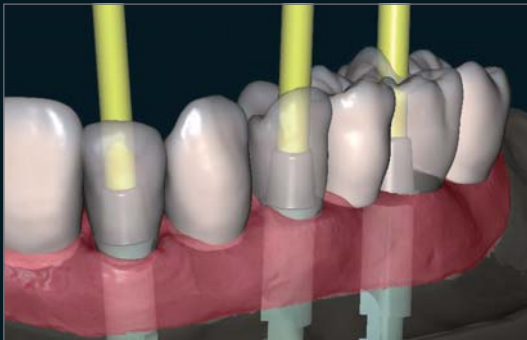

THE CAD/CAM OCCLUSALLY SCREWED BRIDGES SOFTWARE MODULE

- *Module for the creation of occlusally screwed bridges and bars with individual profiles*
- *Free shaping of the emergence profile, taking into account the anatomic tooth shape and gingiva*
- *With the help of the scanbodies, the software calculates the alignment of the already included implants and uses it for the exact alignment of the screw channels*
- *New! Creation of threaded screw channels in the zirconia structure for sealing the restoration with resin screw plugs*
- *Attention – only works in combination with the CAD/CAM Occlusally Abutments software module*

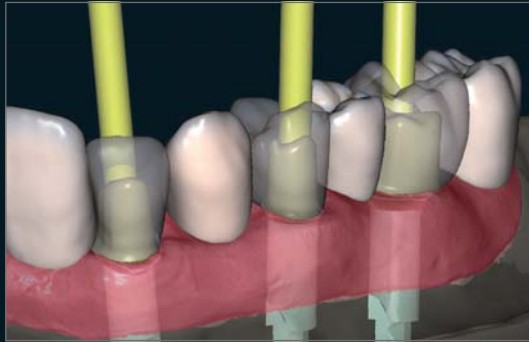

THE CAD/CAM ABUTMENTS SOFTWARE MODULE

- *Module for the manufacture of individualised abutments and their emergence profile*
- *Creates abutments by taking into account the secondary construction*
- *Adjustable parameters: distance to secondary construction, shrinkage, etc.*
- *Semi-transparent display of the outer tooth form, which makes the creation of abutments much easier*
- *Supports a variety of implant systems stored free of charge, that can be constructed either as directly screwed or as bonded titanium bases*
- *Implant positions that have been defined in the Zirkonzahn.Implant-Planner software can be imported via Scanmarkers and can be used for the production of the model and the provisional (for immediate loading)*
- *Attention – only works in combination with the CAD/CAM Occlusally Screwed Bridges software module*

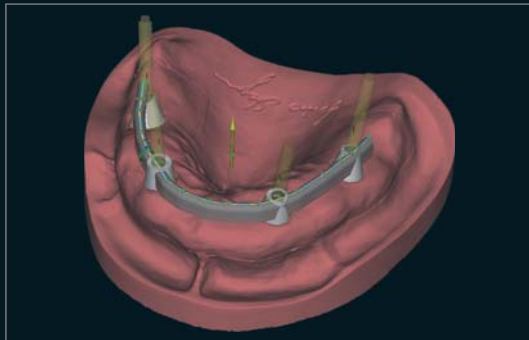

THE CAD/CAM BARS SOFTWARE MODULE

- *Module for the individual manufacture of primary and hybrid bars (also implant-supported)*
- *Freely customisable emergence profile*
- *Semi-transparent display of the outer tooth form or separate situation scans, this greatly facilitates the manufacture of bars*
- *Different types of bars which can easily be modified*
- *Adjustable parameters: Height, thickness, lingual and buccal angle, minimum size and thickness as well as many other individualisation options*
- *Fixing of attachments and retentions is possible as well as blanking out holes and anchorages*

SOFTWARE APPLICATION

Our software supports more than 100 implant systems and always designs the bars in relation to the secondary structure. The two software modules “Bars” and “Occlusally Screwed Bridges” complement each other impeccably, giving technicians extensive operational freedom. Any kind of restoration from single crowns to 14-unit occlusally screw-retained full-contour zirconia bridges – everything can be manufactured with the Zirkonzahn CAD/CAM system in one’s own laboratory.

EXAMPLE: MODELLING A PRETTAU® BRIDGE WITH CEMENTED TITANIUM BAR ON SIX IMPLANTS

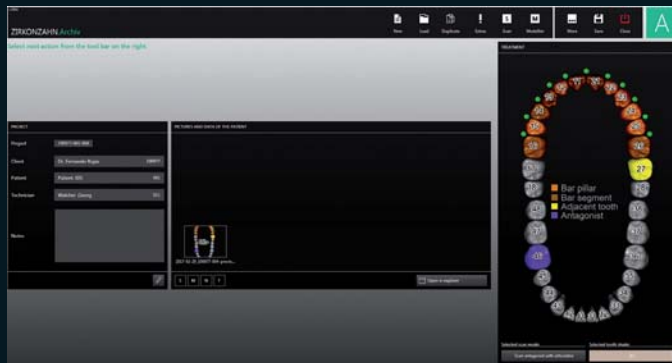

Creation of the patient case in the Zirkonzahn.Archiv software.



After selecting the kind of restoration, all suitable materials and appropriate parameters for the realisation of the restoration will be displayed.

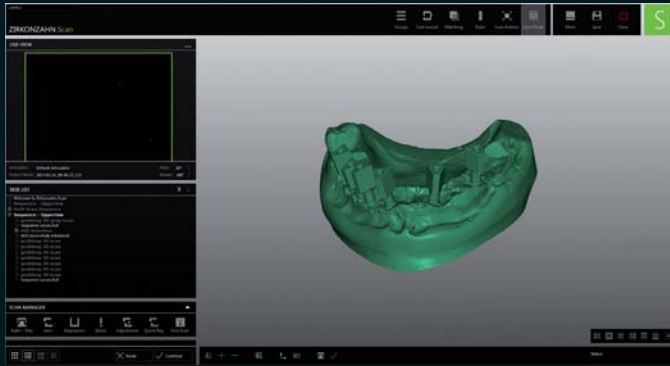

The master model including the attached scanmarkers is scanned with the S600 ARTI scanner and then transferred into the Zirkonzahn.Scan software.

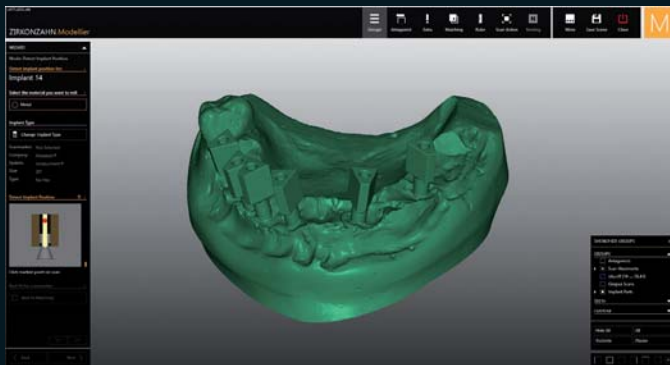

The virtual model is automatically uploaded into the Zirkonzahn.Modellier modelling software.

At this point, the implant system and, if required, the titanium bases can be selected.

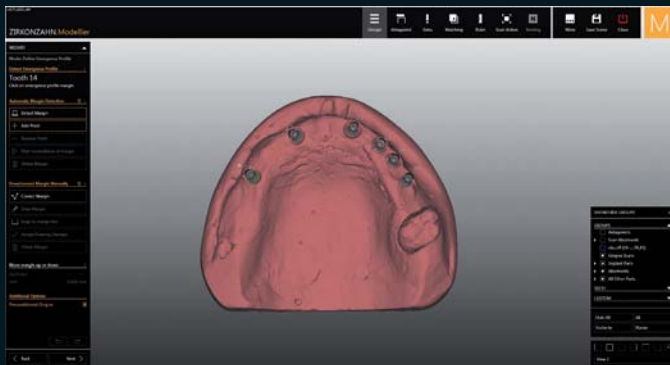

In order to identify the emergence profiles, four points on the margins of the implants have to be defined according to a predefined sequence.

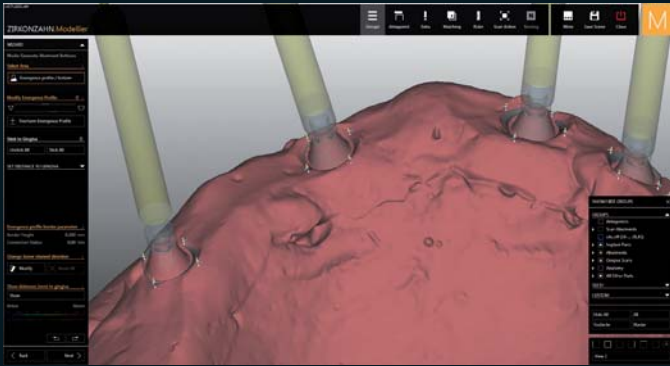

Creation of the emergence profile.

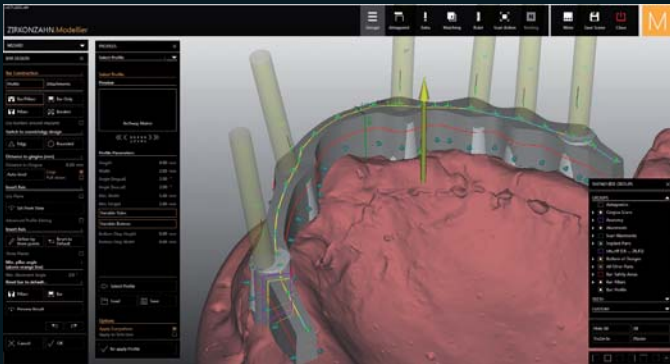

*The bar is brought in the right position.
The posts and the parameters of the bar
can be individually defined.*

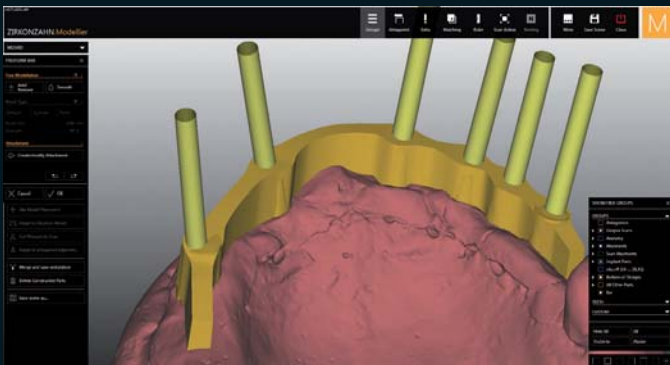

*If desired, the bar can now be smoothed
or occlusally modified.*

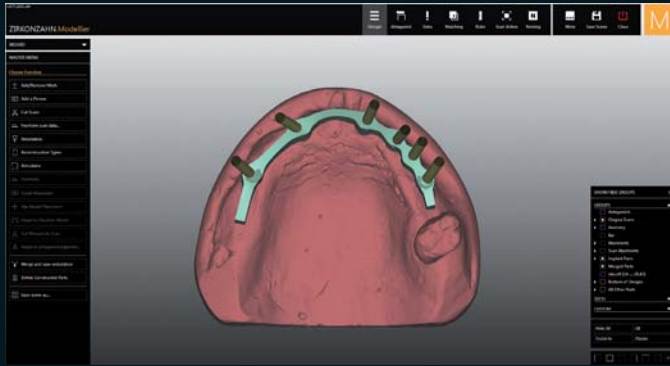

In this working step, the modellation is matched and can be loaded into the Zirkonzahn.Nesting software.

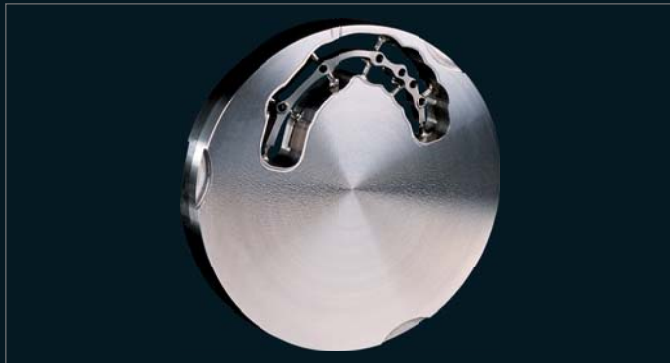

Milled titanium bar in the material blank.



In order to reduce the grey value of the titanium, the parallelised bar is gold-plated by means of the Titanium Spectral-Colouring Anodizer.



For the adaptation of the wax-up to the bar, the patient case is once again saved in the Zirkonzahn.Archiv software.

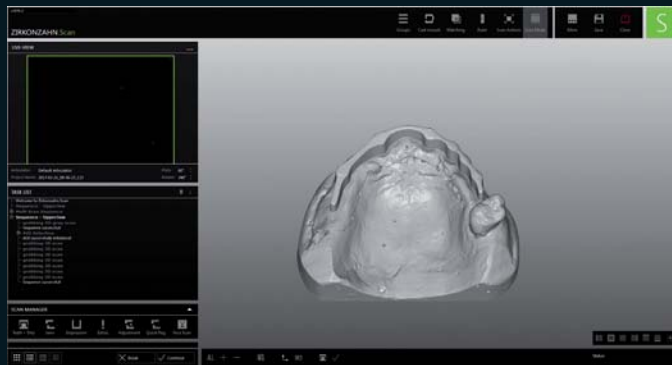

Now, the bar is digitised by means of the S600 ARTI scanner and the Zirkonzahn.Scan software.



After the scanning process, the virtual model and the bar are automatically loaded into the Zirkonzahn.Modellier modelling software.

The preparation line for the wax-up is set on the bar.

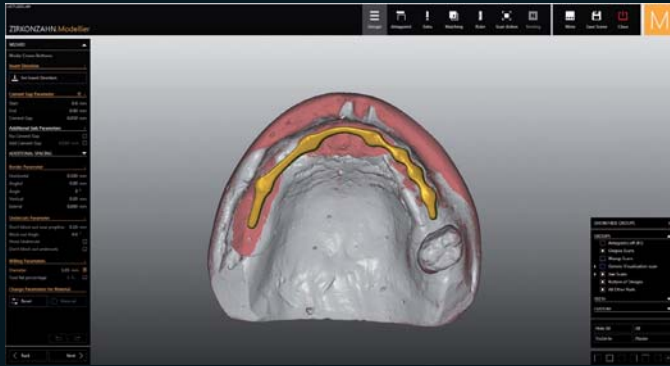

Subsequently, the insertion direction for the secondary structure is set.

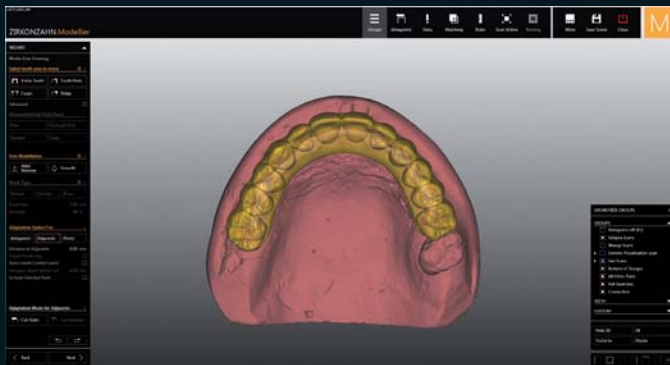

The scanned wax-up is automatically adapted to the bar and can then be freely modified, if necessary.

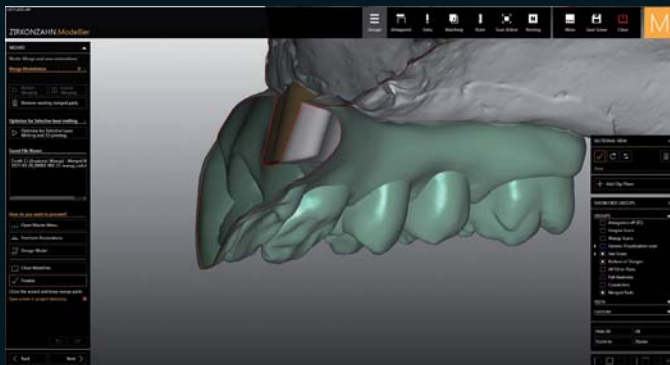

The wax-up adjusted to the bar.



The final modellation is laser-melted for a second free shaping.

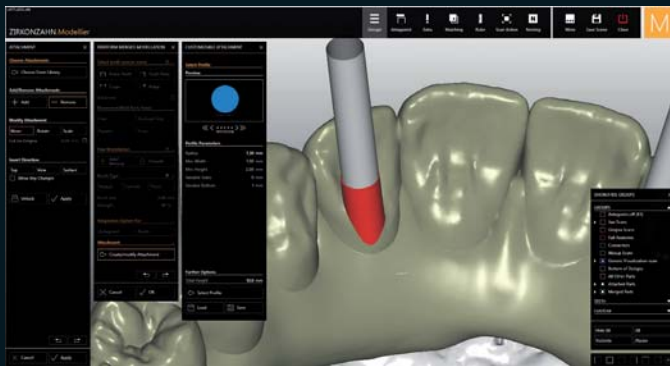

In this working step the screw channels can be blanked with the “attachment” function.



Now, the finished wax-up can be loaded into the Zirkonzahn.Nesting software together with the blanked screw channels. Finally, the milling is carried out.

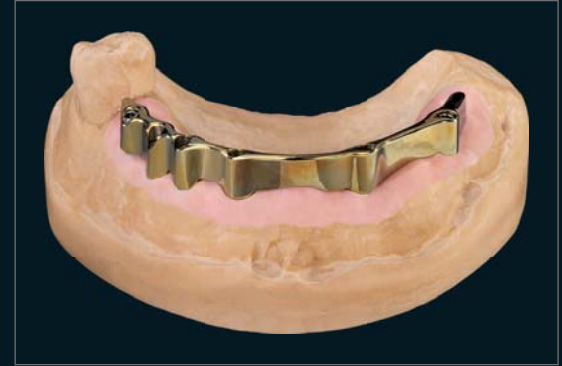
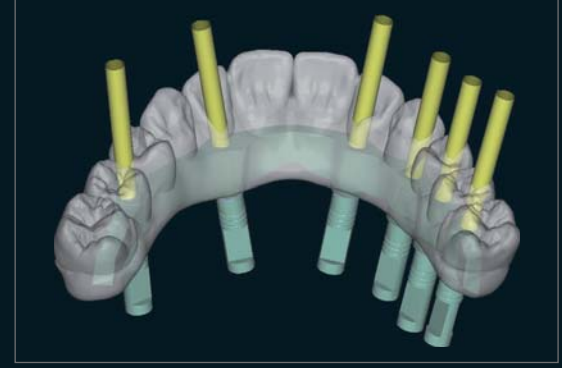

Zirkonzahn®

IMPLANT PROSTHETICS

Zirkonzahn S.r.l – An der Ahr 7 – 39030 Gais/South Tyrol

Zirkonzahn Worldwide – T +39 0474 066 680 – F +39 0474 066 661 – www.zirkonzahn.com – info@zirkonzahn.com



WEAA2321=

All information is subject to change. Errors and omissions excepted. Version: 18/05/2018

ENGLISH